



Instr. No. 2650-369N

INSTALLATION INSTRUCTIONS ELECTRICAL TACHOMETERS

MODELS 19201, 19202, 19204, 19208, 19211, 19214,
19231, 19232, 19233, 19235, 19236, 19255, 19300, 19301,
19302, 19304, 19305, 19310, 19311, 19312, 19324, 19325



Important Notes

1. This tachometer has an air core meter. The tach pointer may not always rest at zero. This is normal. When engine is started, pointer will position on the correct rpm.
2. These tachometers (except model 19208) are water resistant on the face only. This includes normal washing, even moderate pressure washing. It has not been designed to receive extreme water pressure or any washing on the back side of the tachometer. We strongly recommend that you take precautions to protect the back side of the product from these conditions. In order to prevent condensation, instruments require ventilation; this results in points of entry for mud and water through the backside. The back of the water resistant tachometer must be protected in mud or dirt racing. Failure to take these precautions may result in voiding product warranty.
3. Solid core ignition wires may cause tach interference.
4. Under-charged battery may cause incorrect tach operation. Also avoid connecting tach in series with ballast resistor or resistance wires to a 12 V+.
5. Avoid positive side of coil for green wire.
6. Isolate tachometer wires from ignition source.
7. When charging battery, make sure power source to tach is disconnected.
8. Do not use dry cell batteries as a power source for this tachometer.
9. Tachometer wiring should be run inside insulated housing.
10. Use only supplied mount or see mounting options under 19300-19301 series. Others may void your warranty.
11. Ignition manufacturers recommend that the ignition and coil be matched according to criteria which they establish (often the ignition and coil are products of the same company.) If they are mismatched, minor malfunctions may occur, showing as erratic readings on the tach. Mismatching coil and ignition types are often the cause of incorrect tach performance.

Calibration (All Models except Model 19233)

Your Pro-Cycle tachometer is calibrated for 1 and 2 ignition pulses per revolution. If used on a 1 pulse per revolution system, cut the brown wire on the side, so that after it is cut it will be at different lengths (Fig.1). This will allow the wires to lay next to one another and not make contact (Fig.2). After the wire is cut, lay them next to the other wires, and slide the tube over them and into the grommet (Fig.3). Slide the tubing by holding the wires after the tube with one hand. Grab the tube with other hand and push apart. After tubing is in the grommet, use the supplied nylon wire tie on the exposed wires to prevent the tube from coming out of the grommet (Fig.4). If used on a 2 pulse per revolution system, the procedure is the same as 1 pulse per revolution except don't cut the brown wire.

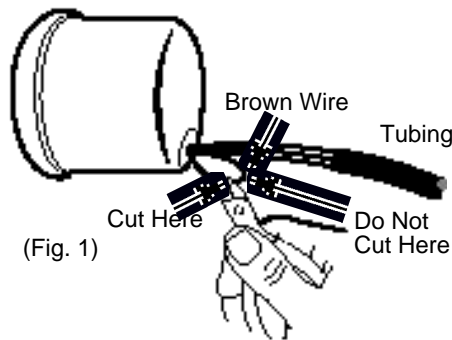

(Fig. 1)

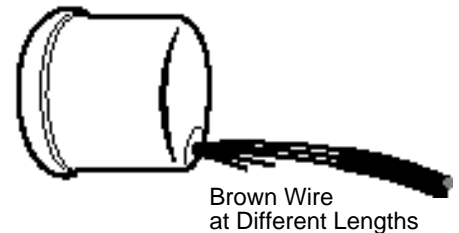

(Fig. 2)

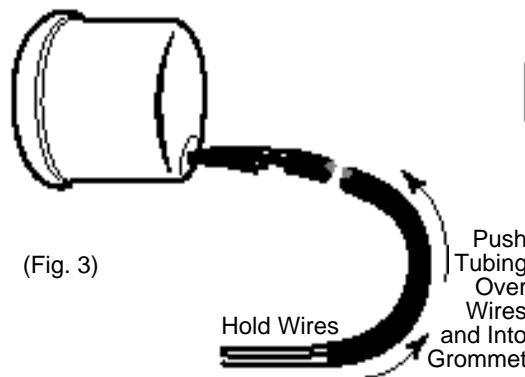

(Fig. 3)

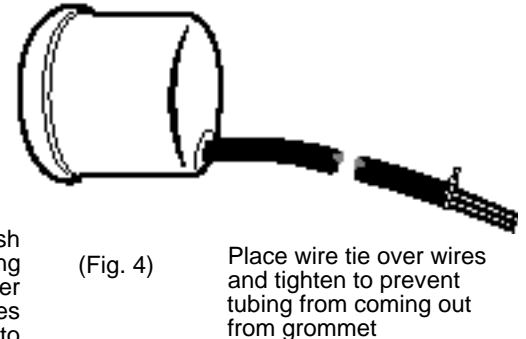

(Fig. 4)

Maintenance

Optional Tachometer Cover

Now that you have purchased your new tachometer, protect your investment from corrosive dirt and moisture. This attractive cover is constructed of durable nylon. A handy drawstring easily secures to the tachometer.

(NOT RECOMMENDED FOR 19304, 19305, 19324, or 19325) For more information contact Auto Meter or see your local distributor.



Model 5241

Mounting

In-Dash Mini-Sprint Bracket 5230

1. Cut a $4\frac{1}{16}$ " hole in dash and insert adapter.
2. Use adapter as a template to mark four $\frac{5}{32}$ " holes on dash for mounting. Remove adapter and drill holes.
3. Mount adapter using four No. 6 screws provided.
4. Insert tachometer hook-up wires through 5230 shock mounting to engine side of dashboard. Use rubber grommets where wires pass through firewall.
5. Peel backing from the four foam-rubber strips provided and adhere them to inside of adapter ring. Apply Pliobond adhesive (available at most hardware stores) to the strips and slide tachometer into adapter, keeping wires away from Pliobond.
6. Check tachometer mounting to be sure tachometer contacts ONLY the rubber pads. If it touches any other part of the car, vibration will be transmitted to tachometer, bypassing the shock mounting.
7. Once Pliobond has dried, tachometer can be removed easily from dash by loosening the No. 6 screws and lifting out shock mounting

Motorcycle Bracket 19240

1. Drill holes in tach mount to match your mounting holes on your triple tree.
2. Bolt tach mounting bracket securely in place.
3. Line up holes on tach base with holes on tach mount. Position the $\frac{1}{4}$ "-20 head screws through mounting bracket and tach base. Tighten with the $\frac{1}{4}$ "-20 acorn nuts.
4. For memory tachometer models, position decal. Install remote switch through back of mounting bracket and tighten with nut. Push on the

Models 19236

Mounting Switch to Switchplate

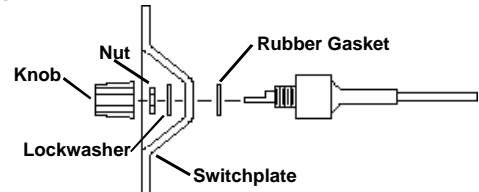

Mounting Switch to Dash

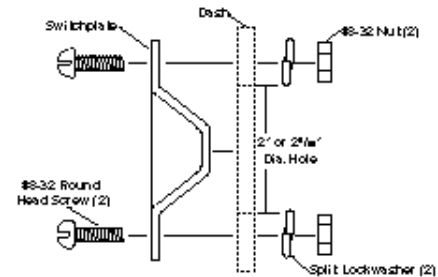

Models 19300, 19301, 19302, 19304, 19305, 19310, 19311, 19312, 19324, 19325

Auto Meter recommends using mounting brackets from Cycle Performance Products with these tachometers. Other styles are available from Yankee Engineuity, 50's Boy and ART Supply. Please see individual manufacturers instructions for directions on mounting your tachometer.

Wiring

Note: Light is always on when power is supplied.

1. The tachometer requires 12 volts to operate.
2. All wire connections should be clean and tight.
3. Red wire should be connected to accessory side of ignition switch.
4. Black wire should be connected to good engine or chassis ground.

WARNING
Do not connect red wire to coil. Only connect to ignition switch or battery and through separate switch.

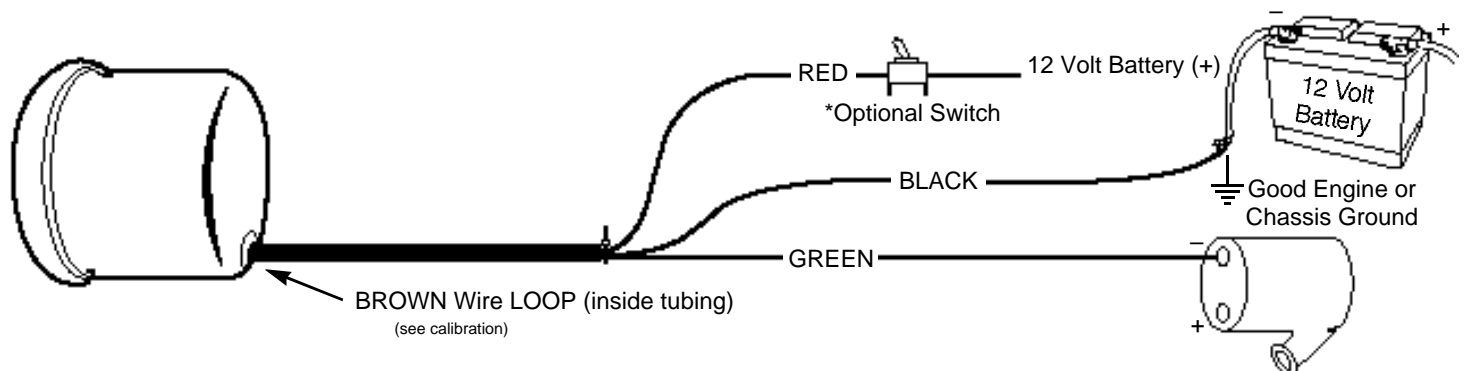

***Optional Switch:** 12 volt power must be supplied to the tachometer to maintain the memory function. It may be desirable to power the tach from a battery with a tach on/off switch.

Models 19304, 19305, 19324, 19325

Note: Light is always on when power is supplied.

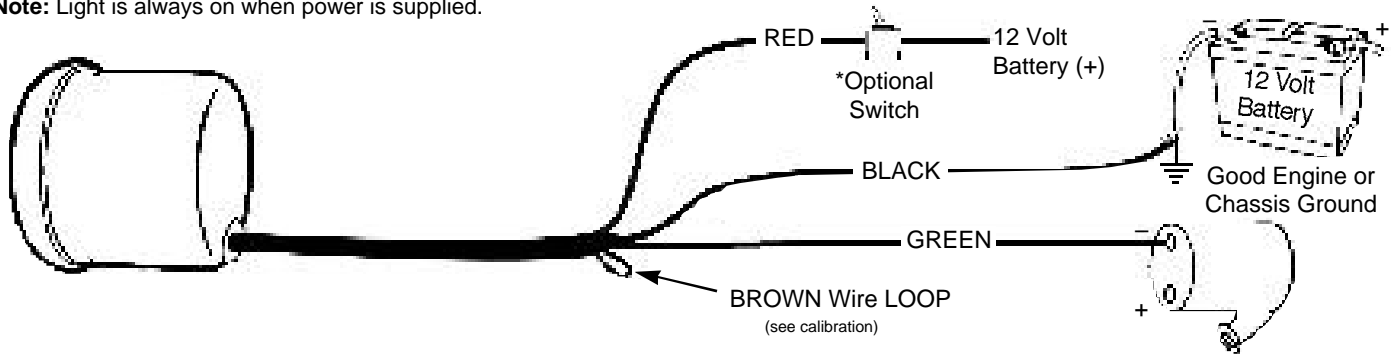

***Optional Switch:** 12 volt power must be supplied to the tachometer to maintain the memory function. It may be desirable to power the tach from a battery with a tach on/off switch.

Harley Davidson Performance/Single Fire Ignition

NOTE: This tachometer operates on standard, factory electronic and high performance electronic racing ignitions, such as Dyna-S and MSD. Not for use on Super Mag Ignitions or any other type of Magneto Ignitions. On electronic ignitions, connect green wire to tach terminal.

WARNING
Do not connect red wire to coil. Only connect to ignition switch or battery and through separate switch.

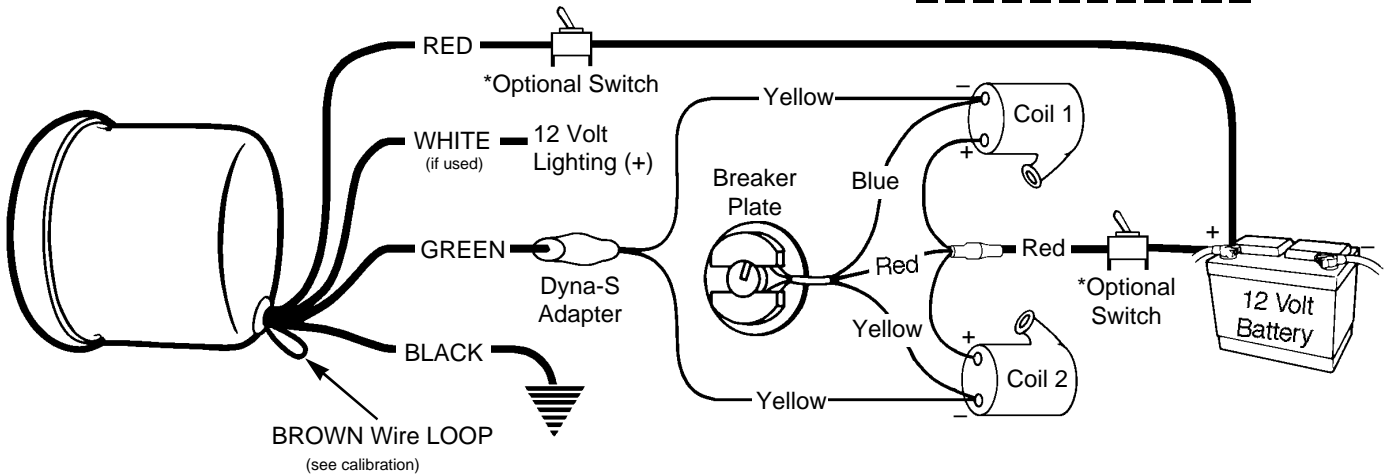

***Optional Switch:** 12 volt power must be supplied to the tachometer to maintain the memory function. It may be desirable to power the tach from a battery with a tach on/off switch.

Sprint Mag Model 19233

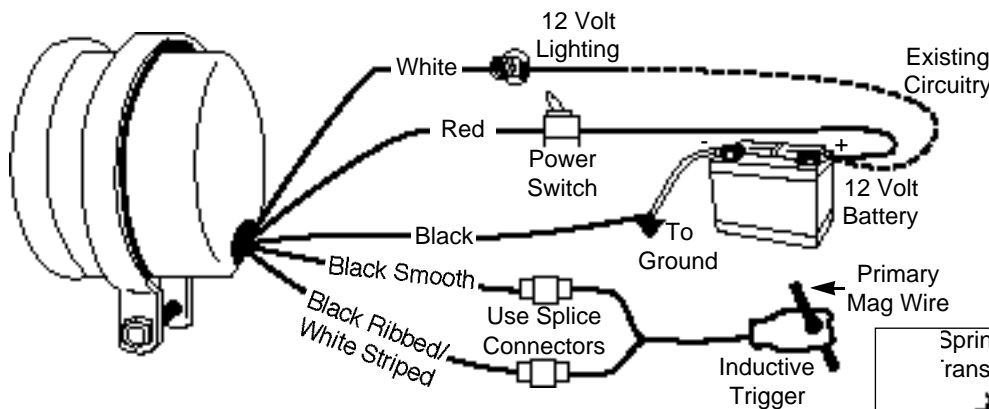

WARNING
Do not connect red wire to coil. Only connect to ignition switch or battery and through separate switch.

Lamp Replacement: Auto Meter No. 3216 or GE No. 53.

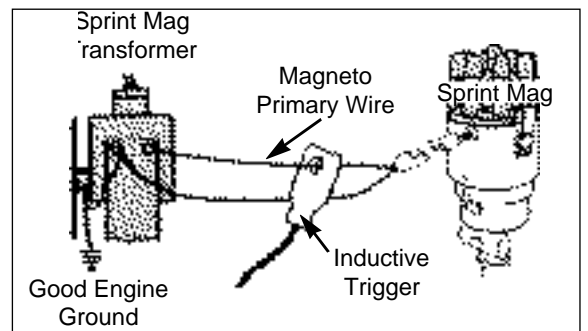

Shift-Lite (Model 19208 not water resistant)

To operate the Pro-Cycle Shift-Lite tachometer, first determine your engine's shift point for maximum horsepower (see warning below). Adjust the SET knob to this RPM. During normal operation, when the tachometer pointer reaches the set point, the amber Shift-Lite will come on. It will stay on until the engine speed drops below the set point. You may adjust the SET knob to a lower RPM for a brief system check before racing. Return to desired set point and your Shift-Lite tachometer is ready to operate.

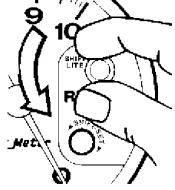

For Shift-Lite tach replacement bulb order model number 3218.

To replace old shift-lite bulb, first turn lens cover counter-clockwise and remove. Pull out old bulb and insert new one. To replace lens cover, line up locking tabs and turn clockwise.

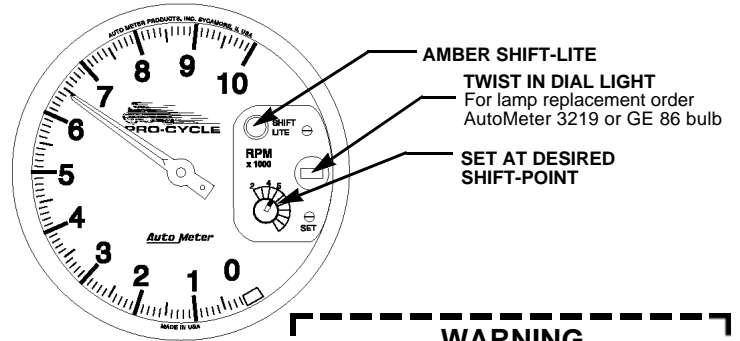

WARNING
Check with engine builder for maximum recommended safe shift point before setting shift point on tachometer. Failure to do this could lead to over-revving of engine, causing serious damage to engine and motorcycle.

Operating Memory Feature

Model 19236

Memory tachometers record the highest RPM reached during each race. Recall your RPM using dash-mounted remote memory switch. Operate switch as shown here.

Use As Tach

Race with the switch in "TACH" position. The tach will function as normal to monitor engine RPM.



Recall RPM

Switch to "RECALL" to display peak RPM. This can be done during or after a race. To clear for next race, see Erase Memory step. **IMPORTANT: See Powering Your Tach Below.**



Erase Memory

Switch to "ERASE" mode before each race. This clears previous runs from the memory. Recording will begin when switch is returned to TACH mode.



Powering Your Tach

NOTE: 12V power must be supplied to the tachometer to maintain the memory function. Power can come from a battery with a tach on/off switch.

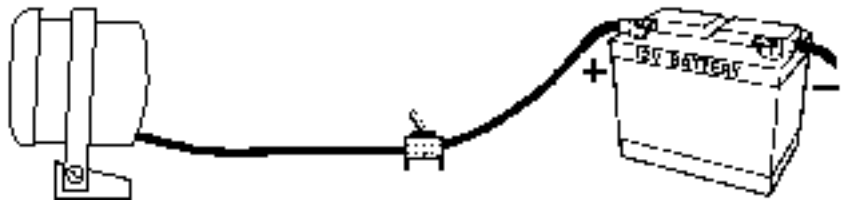

SERVICE

For service send your product to Auto Meter in a well packed shipping carton. Please include a note explaining what the problem is along with your phone number. Please specify when you need the product back. If you need it back immediately mark the outside of the box "RUSH REPAIR," and Auto Meter will service product within two days after receiving it. (\$10.00 charge will be added to the cost of "RUSH REPAIR.") If you are sending product back for Warranty adjustment, you must include a copy (or original) of your sales receipt from the place of purchase.

12 MONTH LIMITED WARRANTY

Auto Meter Products, Inc. warrants to the consumer that all Auto Meter High Performance products will be free from defects in material and workmanship for a period of twelve (12) months from date of the original purchase. Products that fail within this 12 month warranty period will be repaired or replaced at Auto Meter's option to the consumer, when it is determined by Auto Meter Products, Inc. that the product failed due to defects in material or workmanship. This warranty is limited to the repair or replacement of parts in the Auto Meter instruments. In no event shall this warranty exceed the original purchase price of the Auto Meter instruments nor shall Auto Meter Products, Inc. be responsible for special, incidental or consequential damages or costs incurred due to the failure of this product. Warranty claims to Auto Meter must be transportation prepaid and accompanied with dated proof of purchase. This warranty applies only to the original purchaser of product and is non-transferable. All implied warranties shall be limited in duration to the said 12 month warranty period. Breaking the instrument seal, improper use or installation, accident, water damage, abuse, unauthorized repairs or alterations voids this warranty. Auto Meter Products, Inc. disclaims any liability for consequential damages due to breach of any written or implied warranty on all products manufactured by Auto Meter.

FOR SERVICE CONTACT: AUTO METER PRODUCTS Inc. 413 W. Elm St., Sycamore, IL 60178 USA (815)895-8141 or Email us at procycle@autometer.com