

## General Information

This electronic speedometer utilizes a LCD to display odometer and trip odometer mileage. Momentarily pressing of the Trip/Reset button on the dial window toggles the odometer/trip odometer information displayed on the LCD. Pressing the button, while in trip mode, for more than two seconds will reset the trip odometer. The odometer cannot be reset.

This Auto Meter electronic speedometer is pre-calibrated for 16,000 pulses/mile. When converting from a cable driven speedometer, no further calibration is needed if:

1. The transmission's speedometer cable take off is 1000 RPM at 60 MPH. Most vehicles meet this requirement. If the vehicles tire size and/or differential ratio has changed, the speedometer needs to be recalibrated.
2. The vehicle is equipped with a 16-pulse/revolution sender.

(See Speedo Senders below for available Auto Meter Senders.) If the above conditions have not been met, the speedometer must be recalibrated. **(see calibration section)**

**NOTE:** The odometer on this speedometer will read from 1 to 5 miles. This is done during factory testing to insure optimum quality.

## Speedometer Senders

The speedometer is designed to operate with an electrical speed sender. The speed senders signal pulse range must be between 500 and 400,000 pulses/mile. Any speed sender or electronic module that meets the following two conditions can be used:

- Pulse range generated proportional to the vehicle speed
- Output within the voltage ranges listed below:
  - 2.0 to 16V peak (Square Wave), 3 wire
  - 2.0 to 120V peak to peak (Sine Wave), 2 wire

Recommended Auto Meter Hall-Effect (Square Wave), 3 wire, 16 Pulses Per Revolution senders:

- 5291 Standard 7/8-18 thread
- 5292 Ford, plug in

## Mounting

1. Mount a 3<sup>3</sup>/<sub>8</sub>" speedometer in a 3<sup>3</sup>/<sub>8</sub>" dia. hole and a 5" speedometer in a 4<sup>5</sup>/<sub>16</sub>" dia. hole in the dashboard. (be careful not to make the hole too large.)
2. Cut a <sup>3</sup>/<sub>8</sub>" dia. hole in the firewall for the speedometer wires. Place a rubber grommet in the hole and route the connector wires through the grommet to the engine compartment.
3. Connect the speedometer wires as shown in the wiring section.
4. Secure the speedometer to the dashboard using the provided bracket, and hardware.

**Note:** With the ignition switch off, the speedometer pointer may not always rest at zero. This is normal. When engine is started, the pointer will first move to half scale then will rest at zero.

**WARNING**

Incorrect hookup will damage the speedometer and void warranty. Please read these instructions carefully.

**CAUTION!**

As a safety precaution, the power wire to this product should be fused before connecting it to the positive (+) side of the 12 VDC battery. We recommend using a 4 Amp, 3 AG fast-acting type cartridge fuse (Littlefuse® #312 004 or an equivalent) inline with the power wire to our product.

### 3<sup>3</sup>/<sub>8</sub>" Models

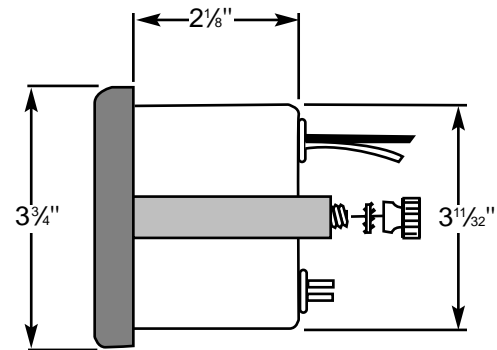

### 5" Models

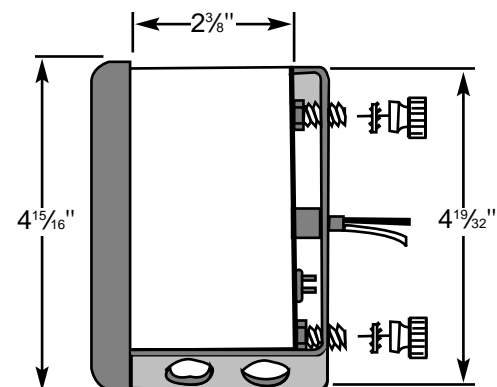

Once the speedometer is mounted and wired into the vehicle, the speedometer should be tested to verify the electrical connections are working properly. First, watch the speedometer's pointer as the power is applied. The pointer should first move to a midrange position, then down to the zero box on the dial. This action verifies that power is properly connected to the speedometer. The vehicle should be driven some distance to verify the Vehicles Speed Sender (VSS) is connected properly, and that the pointer moves. If the pointer does not move off the zero box, verify the VSS is connected properly.

## Calibration

(Only needed if the conditions in General Information are not met.)

**Calibration Range:** 500 to 400,000 pulses/mile

1. Speedometer and sender must be installed.
2. To set the speedometer in calibration mode; press and hold the Trip/Reset button while starting the engine, then release the Trip/Reset button. The pointer will then move to full scale.

3. Go to the beginning of a known two-mile distance and stop. Press and release the Trip/Reset button. The pointer will move to half scale and is ready for calibration.

**Note:** The accuracy of the speedometer depends on the accuracy of the measured two-mile distance.

4. Drive the two-mile distance and stop. Press and release the Trip/Reset button. The calibration mode will be exited and the pointer will return to 0 mph.

Calibration is complete!

**This is a list of factors that can affect speedometer accuracy and how to minimize them during calibration.**

1. Tires slightly increase in diameter as vehicle speed increases. To minimize this error drive at an average speed during calibration. (Approx. 45 mph for most street vehicles.)
2. Tires slightly increase in diameter as air pressure is increased. To minimize this error, check the tire to ensure correct air pressure.
3. The diameter of the tires change with vehicle load. Minimize this error by having an average load in the vehicle during calibration.
4. Tire slippage. Minimize this error by not breaking traction.
5. Accuracy of 2 mile distance driven during calibration. Minimize this error by verifying the distance.

**Note:** Always recalibrate speedometer after any tire size or differential ratio change.

## Wiring

Use 20 AWG stranded or heavier wire for hook-up

### Auto Meter Hall-Effect senders (Square Wave)

- Models 5291 (standard 7/8-18 thread) & 5292 (For Plug in Sensor), 3 wire sender, cruise.

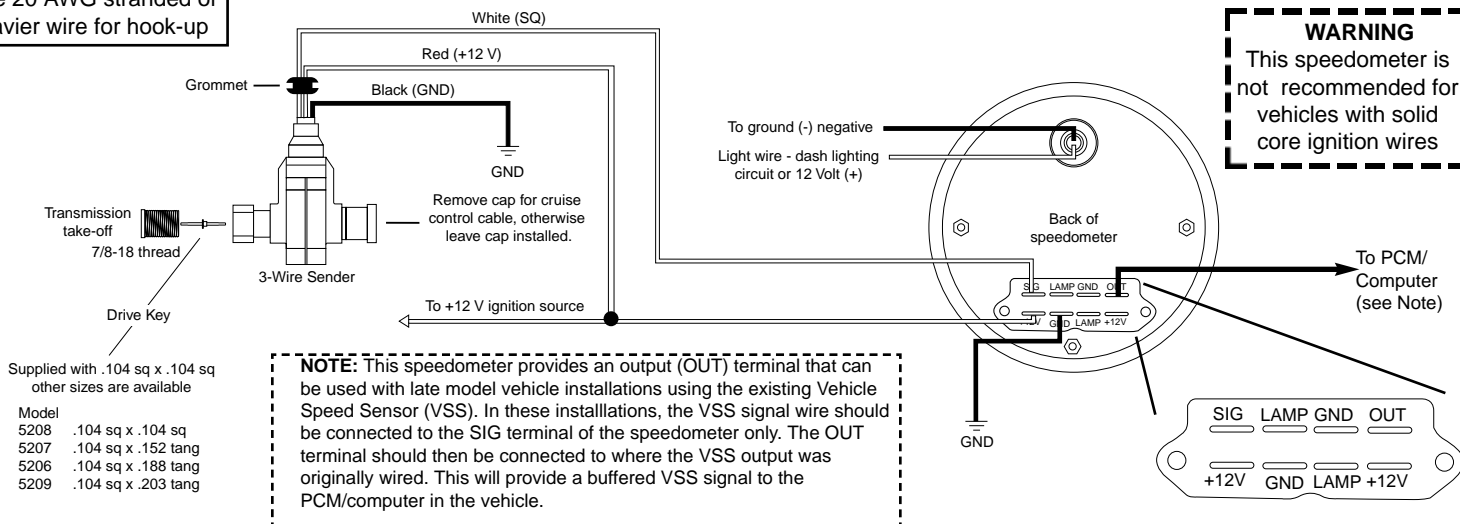

### Most OEM style or Factory Installed, 2 wire senders (Sine Wave)

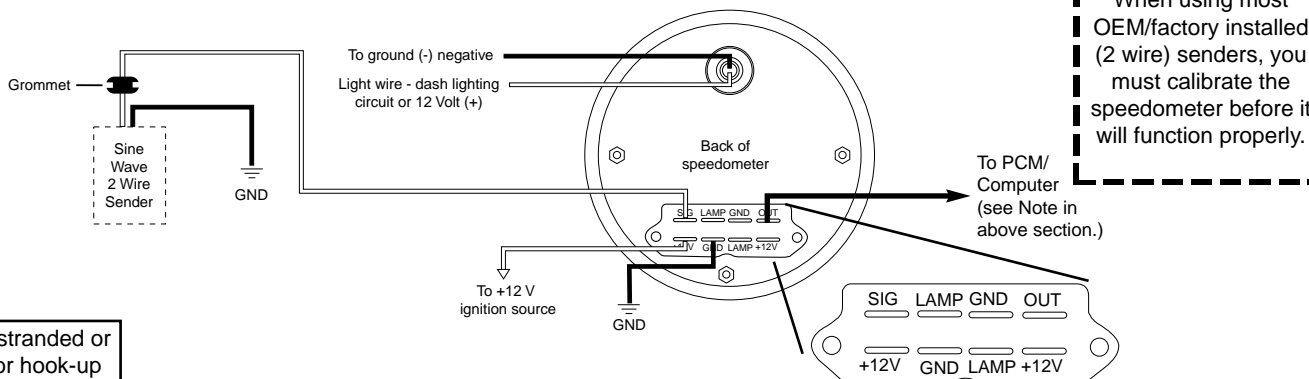

## SERVICE

For service send your product to Auto Meter in a well packed shipping carton. Please include a note explaining what the problem is along with your phone number. Please specify when you need the product back. If you need it back immediately mark the outside of the box "RUSH REPAIR," and Auto Meter will service product within two days after receiving it. (\$10.00 charge will be added to the cost of "RUSH REPAIR.") If you are sending product back for Warranty adjustment, you must include a copy (or original) of your sales receipt from the place of purchase.

### 12 MONTH LIMITED WARRANTY

Auto Meter Products, Inc. warrants to the consumer that all Auto Meter High Performance products will be free from defects in material and workmanship for a period of twelve (12) months from date of the original purchase. Products that fail within this 12 month warranty period will be repaired or replaced at Auto Meter's option to the consumer, when it is determined by Auto Meter Products, Inc. that the product failed due to defects in material or workmanship. This warranty is limited to the repair or replacement of parts in the Auto Meter instruments. In no event shall this warranty exceed the original purchase price of the Auto Meter instruments nor shall Auto Meter Products, Inc. be responsible for special, incidental or consequential damages or costs incurred due to the failure of this product. Warranty claims to Auto Meter must be transportation prepaid and accompanied with dated proof of purchase. This warranty applies only to the original purchaser of product and is non-transferable. All implied warranties shall be limited in duration to the said 12 month warranty period. Breaking the instrument seal, improper use or installation, accident, water damage, abuse, unauthorized repairs or alterations voids this warranty. Auto Meter Products, Inc. disclaims any liability for consequential damages due to breach of any written or implied warranty on all products manufactured by Auto Meter.

FOR SERVICE SEND TO: AUTO METER PRODUCTS, INC. 413 W. Elm St., Sycamore, IL 60178 USA (815) 895-8141  
Email us at [service@autometer.com](mailto:service@autometer.com)