

**NOTE**

Due to normal manufacturing processes you may have "flashing" (small fibers of plastic) around the pod holes. Once the gauge(s) are installed in the pod you will not be able to see the "flashing."

Installation

The Gauge Works Gauge Cage is designed to directly replace the two ventilation outlets in the center of the dash of your Mustang. Gauge Cages with vents will require a slightly different install, refer to step (3). Follow the instructions carefully and make sure you do not overtighten any screws.

1. Remove Air Registers

Insert a screwdriver between the air register and the side of the vent housing. Carefully pry the register forward and pop it out. You may need to pull the register with your fingers to remove it. Remove both registers. Be careful to not pry the aiming wheels off their mounts and lose any of their pieces.



2. Remove Vent Housing

The vent housing is held in place with (8) plastic clips (4 on top and 4 on the bottom). To remove the vent housing, pull outward on housing. While pulling out, pry each clip up. The clips will stay up as long as outward pressure is applied to vent housing. Pull vent housing out from dash.



3. Prep Air Registers (For Gauge Cages with vents)

Disassemble the register as shown in Fig. A. Using a utility knife, cut the areas specified in the illustration. Repeat these steps for the other register so that you have a pair of them. After cutting them, reassemble the pieces so they resemble the registers shown in Fig. B.

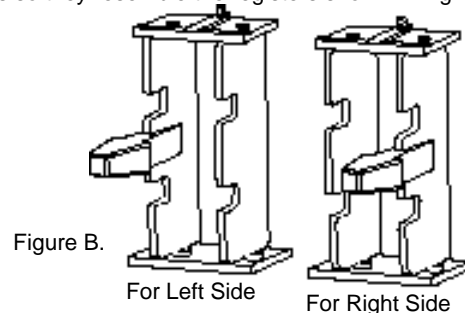
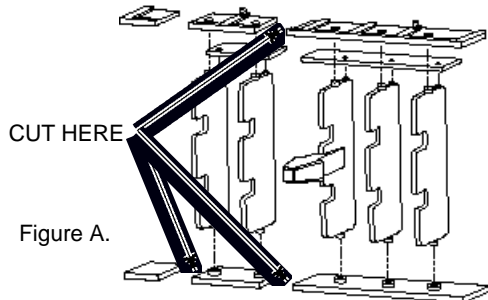

4. Prep Vent Opening

Inside the vent opening and to the left is a dashpad nut. Remove nut and keep it for later use. Trim a quarter to half-inch from the left side of the duct using a utility knife. This allows the instrument leads to pass between the instruments and the duct.



5. Insert Foam Backing (For non-vent models)

Insert provided foam into air duct so that the metal backing strip is facing you. This redirects air traveling to the front vents into the side vents. Skip this step for Gauge Cages with vents. This allows the center air vents to remain functional.



6. Insert Backing Plate

Turn the bracket sideways and insert it in the vent opening. The slot in the bracket should be to the left when properly installed.



7. Position Bracket

Pull bottom edge of bracket down and into position. Then pull top edge up into position. When properly installed, slot on left side of bracket will fit over bolt. Replace nut which was removed earlier.



8. Mounting Instruments in Face Plate

Insert the instruments into the face plate. Place the binder ring over the gauges. Slide the ring down to the face plate until snug. Make sure it is positioned correctly before tightening the screws. The binder ring will hold the gauges secure against the face plate to prevent them from rotating out of position.

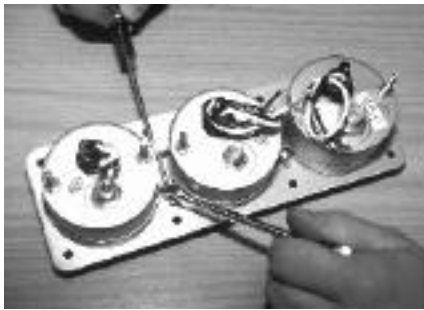

9. Wire and Mount Instruments in Dash

Make all necessary electrical connections. The instrument leads must be bent to the left to clear the dash interior. Some gauges may require angle fittings. Place the assembly into dash. Install the six allen head screws and tighten them until they are snug. **DO NOT OVERTIGHTEN SCREWS!**



While Tightening Screws:

- Make sure the face plate is positioned so that it is running parallel to your dash pad.
- Use a standard screwdriver. **DO NOT USE AN ELECTRIC SCREWDRIVER!**
- Hand tighten screws only until snug.
- Only tighten screws until face plate is flush with recessed area of dash.
- **DO NOT OVERTIGHTEN SCREWS!** You risk deforming or damaging the face plate.
- Check the screws occasionally and retighten as needed.

Auto Meter Gauge Works Three Year Limited Warranty

Gauge Works warrants to the consumer that all Auto Meter Gauge Works products will be free from defects in material and workmanship. Products that fail will be repaired or replaced at Auto Meter Gauge Works' option to the consumer, when determined by Auto Meter Gauge Works that the product failed due to defects in material or workmanship. This warranty is limited to the repair or replacement of parts in the Auto Meter Gauge Works Product and the necessary labor done by Auto Meter Gauge Works to effect the repair or replacement of the Auto Meter Gauge Works product. In no event shall this warranty exceed the original purchase price of the Auto Meter Gauge Works product nor shall Auto Meter Gauge Works be responsible for special, incidental or consequential damages or costs incurred due to the failure of this product. Warranty claims to Auto Meter Gauge Works must be transportation prepaid and accompanied with proof of purchase. This warranty applies only to the original purchaser of product and is non-transferable. Improper use or installation, accident, water damage, abuse, unauthorized repairs or alterations voids this warranty. Auto Meter Gauge Works disclaims any liability for consequential damages due to breach of any written or implied warranty on all products manufactured by Auto Meter Gauge Works. This warranty is made solely by Gauge Works with Auto Meter being the agent to contact for warranty claims. If the partnership between Auto Meter and Gauge Works dissolves, then all warranty adjustments will be covered by the Gauge Works Co.