

Instrument Kit Installation and Wiring Instructions

For Vision, Cockpit, Cockpit White, Cockpit Royale, Series 1, Heritage Gold and Industrial Styles

VDO® Instruments

Winchester, Virginia USA

THE INSTRUCTIONS FOR INSTALLATION AND ELECTRICAL WIRING FOR THE INSTRUMENT KIT FOLLOWS. USE IS RESTRICTED TO 12 VOLT NEGATIVE GROUND ELECTRICAL SYSTEMS.

Parts List		
Item	Description	Quantity
1.	Programmable Speedometer (3 1/8" or 3 3/8" diameter)	1
2.	Voltmeter (2 1/16" diameter)	1
3.	Fuel Gauge (2 1/16" diameter)	1
4.	Pressure Gauge (2 1/16" diameter)	1
5.	Temperature Gauge (2 1/16" diameter)	1
6.	Pressure Sender (3/8" - 27 NPT)	1
7.	Temperature Sender (3/8" - 18 NPT)	1
8.	Fuel Level Sender	1
9.	Float Arm	1
10.	Speed Sensor	1
11.	Spin-Lok™ Mounting Clamp for gauges and speedometer	5
12.	Instrument Kit Installation Instructions	1
13.	Speedometer Installation Instructions	1
14.	3/8" - 18 NPT to 1/2" - 14 NPT adapter	1

Tools and Materials Needed For Installation:

18 Gauge stranded, insulated wire
 Insulated 1/4" spade terminals
 2 1/16" and 3 1/8" or 3 3/8" hole saws
 Drill and drill bit set
 Bolt cutter or similar tool
 Half-round file
 Tape measure or ruler
 Wrench or nut driver set
 Phillips screw driver
 Utility knife
 Gas-proof gasket sealant
 Weld-on Installation Kit (optional) P/N 226 901
 Bolt-on Installation Kit (optional) P/N 226 451
 Optional VDO Mounting Bracket (speedometer only)

CAUTION: Read these instructions thoroughly before making installation. Do not deviate from assembly or wiring instructions. Always disconnect battery ground before making any electrical connections. If in doubt, please contact your dealer or VDO Instruments at (540) 665-2428.

General Information:

These kits come with VDO's Spin-Lok™ Mounting Clamps for easy installation. Optional VDO mounting brackets are available from your VDO dealer, should you require them. Note that the programmable speedometer included in this kit has a special set of installation and operation instructions. These instructions must be followed carefully to insure proper performance of the speedometer.

Gauge Installation:

1. Select mounting locations for all gauges which provide good visibility for the driver. Lay out center points for each instrument on the panel.

2. Cut 2 1/16" (52 mm) diameter holes for the smaller gauges. Place each gauge into its hole to be sure it fits. If the fit is too snug, use a file to slightly enlarge the opening until the gauge fits properly.

3. Make sure each gauge is rotated properly in its hole, and is easy to read. Hand-tighten the gauges with the enclosed Spin-Lok™ Mounting Clamps until the gauges can no longer be rotated by hand in the panel. Diagram A shows a properly mounted gauge.

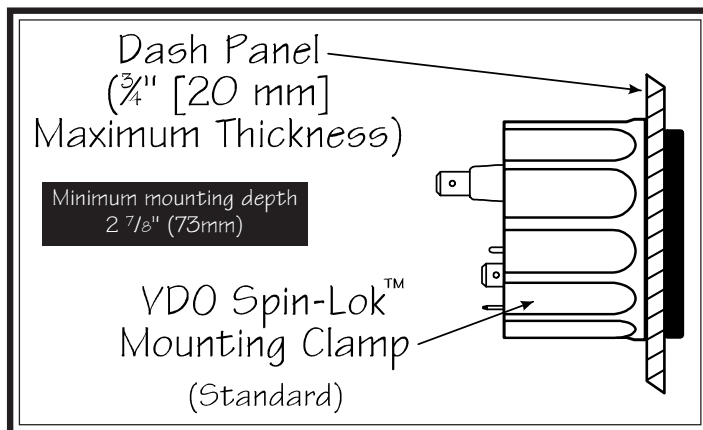

Diagram A

Proper mounting using VDO's Spin-Lok™ Mounting Clamp

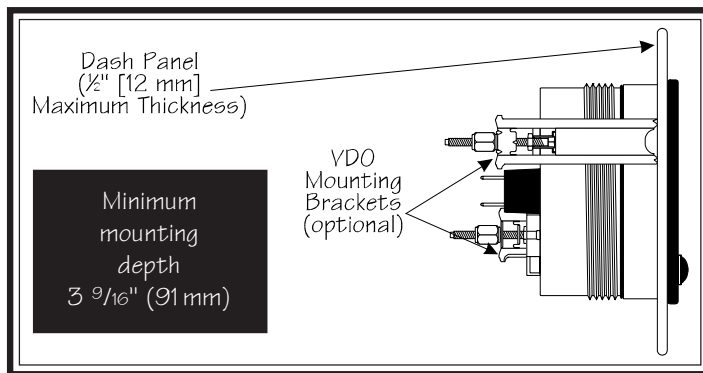

Diagram B

Mounting with Optional Speedometer Mounting Bracket

Speedometer Installation:

PLEASE REFER TO THE SEPARATE PROGRAMMABLE SPEEDOMETER INSTALLATION AND OPERATING INSTRUCTIONS FOR PROPER MOUNTING AND OPERATION OF THE SPEEDOMETER. SEE PAGE 3 FOR INSTRUCTIONS ON INSTALLING SPEED SENSORS.

It is best that you mount the speedometer after you have installed the 2 1/16" (52 mm) gauges. Illumination wiring of the speedometer and the 2 1/16" (52 mm) gauges should be done at the same time. Other wiring should be done in whatever sequence is easiest for you.

Fuel Level Sender Installation

The Fuel Level Sender has a resistance rating of 10Ω when the tank is empty and 180Ω when full. Refer to the VDO Instruments Catalog for matching fuel gauges. The unit can be adjusted to read accurately in tanks from 6" to 23" deep. For sender adjustment, refer to Table 1 and Diagram C.

I. Measure the depth of your fuel tank. Locate this dimension in Column "A" of Table 1. Column "B" then shows the length from the underside of the sender flange to the center of the float pivot. Column "C" shows the distance from the center of the float pivot to the center of the float ball. For example, a tank 12" deep would need a measurement of 6" from the flange to the pivot, and 7.8" from the pivot to the float.

II. For tank depths less than 15½" it will be necessary to eliminate a part of the assembly. Otherwise, proceed to Section III. Refer to Diagram D and proceed as follows:

1. Remove nut "a," washer "b," and ring terminal "c" from the underside of the mounting flange.
2. Remove the two screws marked "d" and discard.
3. Remove the two screws marked "e" from the plastic housing and save for later use.
4. Carefully remove bracket "f" from the plastic housing and discard. Replace it with bracket "g" in the housing and loosely re-install the two screws marked "e" into the housing.
5. Slide the housing up or down until the proper dimension from Table 1 is reached, then tighten the screws "e" securely.
6. Replace the ring terminal and its hardware.

CAUTION: Do not overtighten hardware, to avoid damage to the threads!

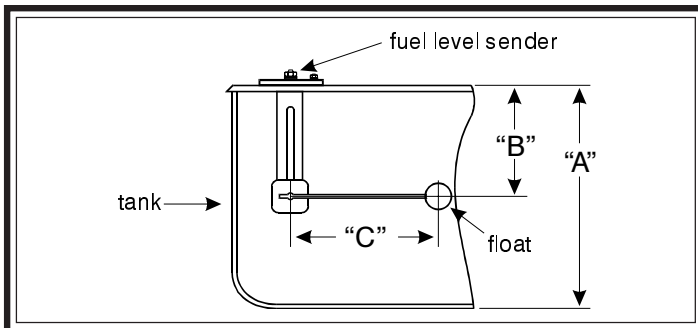

Diagram C

Measurements Needed To Make Proper Adjustments

TABLE 1 (dimensions in inches)								
A	B	C	A	B	C	A	B	C
6.0	3.00	3.5	12.0	6.00	7.8	18.0	9.00	12.0
6.5	3.25	3.8	12.5	6.25	8.1	18.5	9.25	12.3
7.0	3.50	4.2	13.0	6.50	8.5	19.0	9.50	12.6
7.5	3.75	4.5	13.5	6.75	8.9	19.5	9.75	12.9
8.0	4.00	4.9	14.0	7.00	9.3	20.0	10.00	13.4
8.5	4.25	5.3	14.5	7.25	9.6	20.5	10.25	13.8
9.0	4.50	5.6	15.0	7.50	10.0	21.0	10.50	14.2
9.5	4.75	6.0	15.5	7.75	10.4	21.5	10.75	14.6
10.0	5.00	6.4	16.0	8.00	10.7	22.0	11.00	15.0
10.5	5.25	6.7	16.5	8.25	11.0	22.5	11.25	15.4
11.0	5.50	7.1	17.0	8.50	11.4	23.0	11.50	15.7
11.5	5.75	7.4	17.5	8.75	11.8			

!! IMPORTANT !!

As received, the unit will have a short lever arm installed. Loosen the screw and remove the short lever arm, and replace it with the long float arm and plastic float ball assembly.

When the installation is finished, the arm length to the left (short side) of the screw must be 1".

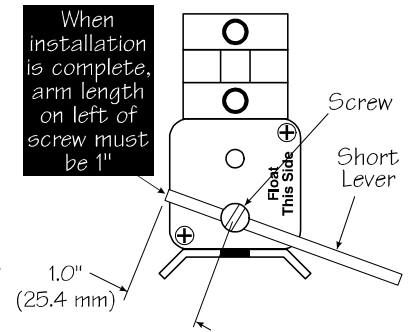

CAUTION: When attaching the float arm to the sender body, make sure the float ball is to the right side as you face the unit, as shown in Diagram D. If you attach the float arm to the left of the sender body, or backwards, the fuel gauge will read "FULL" when the tank is actually empty!

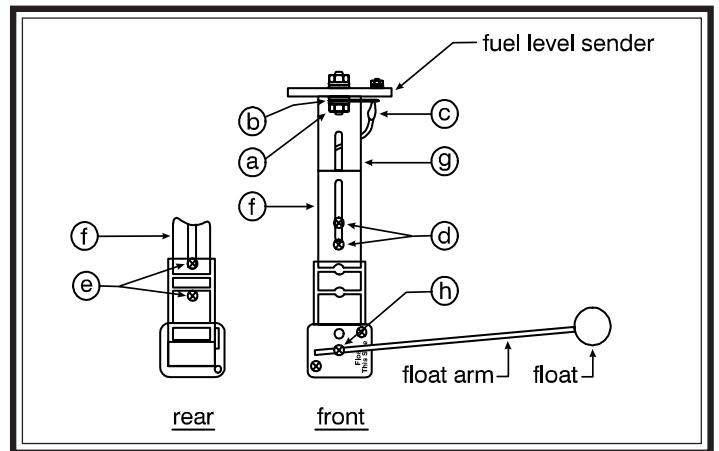

Diagram D

Parts of the Fuel Level Sender Unit to be Adjusted

III. For tank depths of 16" to 23", no disassembly of the sender bracket is necessary.

1. Remove the ring terminal as instructed in Section II, above.
2. Loosen the two screws marked "d." Adjust the plastic housing up or down until the proper dimension from Table 1 is obtained, then retighten the screws securely. **DO NOT** overtighten them.
3. Re-install the ring terminal and its hardware. Again, tighten the hardware securely, but **DO NOT** overtighten.

IV. To install the float assembly, loosen the screw marked "h," remove the short piece of rod, and discard it. Insert the float rod until the proper length—the "C" length from Table 1—is met, then tighten screw "h" securely. Carefully cut off any excess rod with a bolt cutter or similar tool, taking care not to damage the assembly.

NOTE: Make sure the float is installed as shown in Diagram B. Remember, if it is installed backwards, the fuel gauge will indicate "FULL" when the tank is actually empty, and vice-versa. Be sure to leave 1" on the short side of the arm.

V. Refer to Diagram E for installation of the fuel sender assembly into the tank. The sender flange is designed to fit a standard SAE hole pattern.

CAUTION: Before drilling any holes into the tank, place the sender assembly on top of the tank to judge the proper hole placement—one that will allow the float arm clearance inside the tank.

SAFETY PRECAUTION: When making modifications to fuel tanks, it is essential that the tank be removed from the vehicle, and that it is empty, clean and dry. After drilling, make sure all chips and other foreign matter have been removed from the tank. Clean the tank thoroughly.

If no holes exist in the fuel tank (see CAUTION, above):

1. Carefully mark an area to be cut open so you can insert the sender. The key to this step is to position the float as close as possible to the center of the tank. This provides the most stable and accurate reading when the fuel sloshes back and forth. Make sure you have allowed enough clearance for the float arm before you cut the hole. Remember, you only get one chance to do it right!
2. Cut a 1.697" (43 mm) hole in the top of the tank.
3. With the gasket in place below the flange, carefully feed the float arm and sender body into the 1.697" (43 mm) hole in the tank. Make certain the float arm has free motion within the tank. Using the sender flange as a template, locate the positions of the five mounting holes. Depending on the thickness of the tank, either self-tapping screws or #8-32 machine screws may be used, drilling and tapping accordingly. If threaded holes already exist, check the thread size and use the appropriate hardware.
4. Insert the fuel sender assembly into the tank and apply gas-proof sealant. Align the holes and thread in the 1/2" mounting screws through the holes in the sender flange and tank. Check to make sure that all screws are secure. **AVOID OVERTIGHTENING!** When you have done this, the installation of the fuel level sender unit is complete.

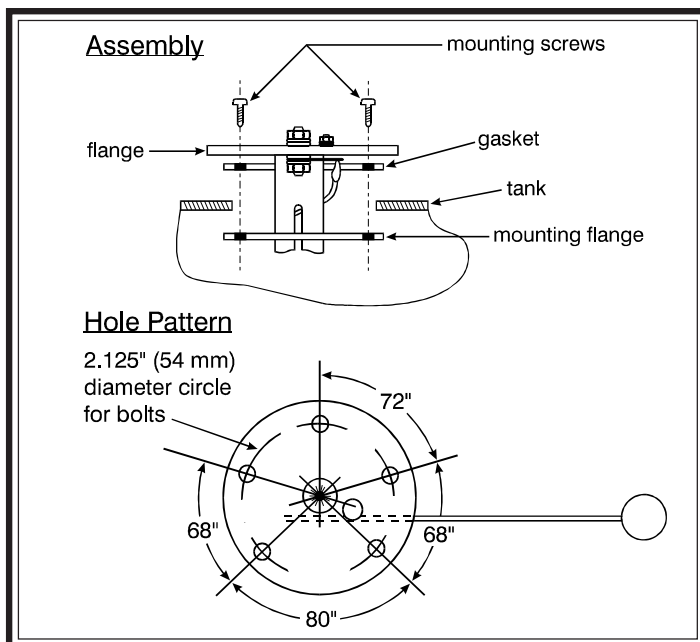

Diagram E

Fuel Sender Assembly and Hole Pattern Dimensions

Temperature and Pressure Sender Installation:

Check the OEM engine manual for the correct location for these senders. Temperature senders are most accurate when installed in an "aftermarket" intake manifold. Installing the sender into the cylinder head can cause high readings due to exhaust manifold heat.

NOTE: This kit contains a 3/8" – 18 NPT temperature sender, and a 3/8" – 18 NPT to 1/2" – 14 NPT adapter should you need it.

CAUTION: Do not use tee, angle or reducing adapters for temperature senders, as the tip may not be immersed in the water flow. Do not use teflon tape on sender threads. It will interfere with the electrical ground. Senders have self-sealing, tapered pipe threads.

Speed Sensor Installation:

The speed sender included for use with the programmable speedometer in this VDO Instrument Kit is a standard, closed Hall-effect sender. It is a closed sender with 7/8" – 18 NPT fittings for GM and many other transmissions. It sends a 16 pulse-per-revolution signal in a three-wire configuration.

(A standard, through Hall-effect sender for use with cruise control is available from your VDO dealer (Part Number 340-012). Other senders which can be used with the programmable sender include Ford [through or closed] Hall-effect senders or almost any inductive sender.)

1. If you are replacing an existing speedometer: Remove the cable that went to the old speedometer.
2. Install the new sender in the place where the old cable was bolted onto the transmission.

or, in a new installation:

1. Bolt the sender onto the transmission at the location specified by the OEM for speedometer cable installation.
2. Run the eight foot length of wire to the new speedometer.
3. Cut it to length, and attach it to the new speedometer according to the instructions in the separate, enclosed speedometer installation and operation instructions.

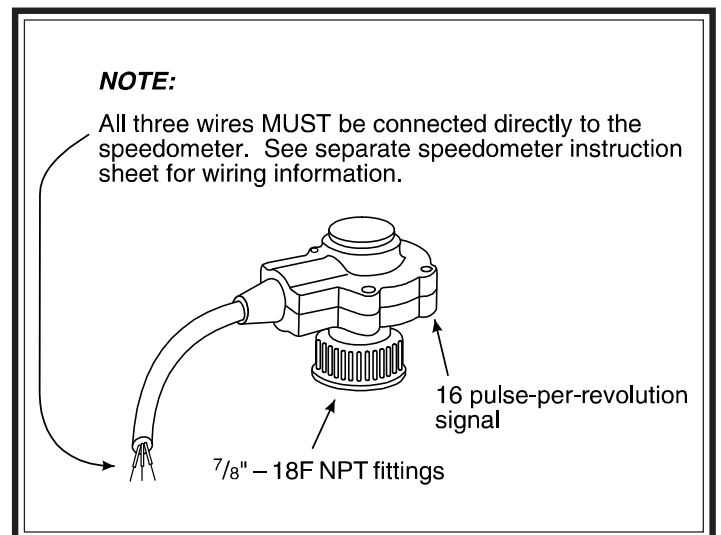

Diagram F

Standard, closed, 3-wire Hall-effect sender included in kit

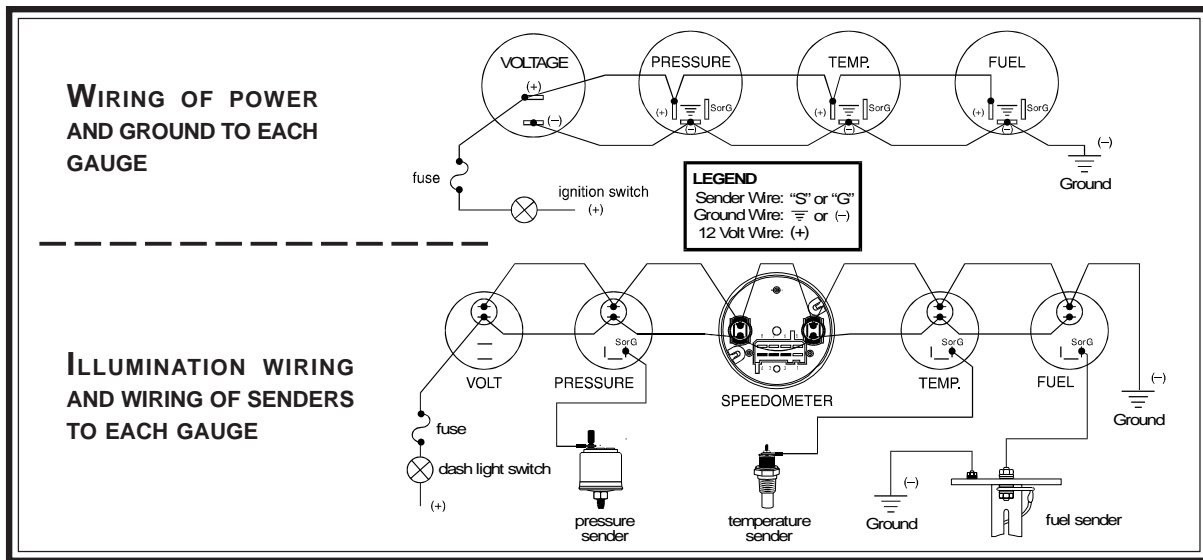

Diagram G
Wiring Diagram

Electrical Wiring:

Refer to the wiring diagram, Diagram G. Wire gauges in series from a positive (+) accessory to a source which is not already overloaded with fans, air conditioning, and such. The ground (-) wire is also run in series, including the light socket ground. The final ground run, using 14-gauge wire, should be connected to a good ground such as the engine block ground strap or directly to the negative battery post.

NOTE: See the separate Speedometer Installation and Operation Instructions for information on wiring the speedometer.

System Testing:

When installation and wiring has been completed, the following tests should be performed to ensure that all systems are functioning properly.

I. Turn on the dash light switch to see if all gauges light up. If not, check your wiring, the ground, and all bulbs. Reconnect or replace as necessary.

II. Turn on the ignition key. Gauges should read:

Pressure: Needle to "0"
 Fuel: Needle to amount of fuel in the tank
 Temperature: Needle to the temperature of the engine water

a) With the key on, pull the sender wire off of the sender:

Fuel and pressure gauges: needle to the right-hand position
 Temperature gauge: needle to the left-hand position

b) With the key on, ground the sender wire to the engine block:

Fuel and Pressure Gauges: needle to the left-hand position
 Temperature Gauge: needle to the right-hand position

NOTE: All VDO electrical gauge pointers will peg full left-hand position when the key is off.

III. Senders can be tested with an ohmmeter that measures from 10Ω to 2000Ω. Connect the positive (+) lead from the tester to the sender terminal, and the negative (-) lead to a good ground. The following readings should occur if the sender is operating properly:

Temperature sender—	engine cold:	700Ω
	engine approximately 180°:	68Ω
Pressure sender—	engine off:	10Ω
	engine running 40 psi:	105Ω
	engine running 60 psi:	152Ω

IV. Voltmeter:

Volts:

Key on, engine off:	12
Engine running, no accessories or lights:	13.7 – 14.3
Engine running with accessories, lights:	13.0 – 14.0

NOTE: These readings are approximate, depending on the regulator system and engine speed. Lower readings indicate a bad battery, regulator, or alternator; or incorrect wiring.

V. With VDO fuel tank senders (Part #226 001), an empty tank will read 10Ω. As fuel is added, the resistance reading will rise until the tank is full, when it will read 180Ω.

NOTE: If you already have a fuel level sender in your tank, check the resistance readings. If they do not match the readings above, VDO manufactures a number of fuel gauges which should match your sender. **REMEMBER:** The ohm range of the sender and the gauge **MUST MATCH!**

VDO Limited Warranty

VDO North America warrants all merchandise against defects in factory workmanship and materials for a period of 24 months after purchase. This warranty applies to the first retail purchaser and covers only those products exposed to normal use or service. Provisions of this warranty shall not apply to a VDO product used for a purpose for which it is not designed, or which has been altered in any way that would be detrimental to the performance or life of the product, or misapplication, misuse, negligence or accident. On any part or product found to be defective after examination by VDO North America, VDO North America will only repair or replace

the merchandise through the original selling dealer or on a direct basis. VDO North America assumes no responsibility for diagnosis, removal and/or installation labor, loss of vehicle use, loss of time, inconvenience or any other consequential expenses. The warranties herein are in lieu of any other expressed or implied warranties, including any implied warranty of merchantability or fitness, and any other obligation on the part of VDO North America, or selling dealer.

(NOTE: This is a "Limited Warranty" as defined by the Magnuson-Moss Warranty Act of 1975.)

VDO Instruments - 188 Brooke Rd. - P.O. Box 2897 - Winchester, VA 22603 - Phone: 540-665-2428