

COLOR CODE

	COLOR	FUNCTION	CONNECT TO:
1	ORANGE	+12v (power)	Dash power, fuse panel, or other switched and fused +12 volt vehicle power source
2	BLACK	Chassis ground, battery (-) (Illumination requires separate ground connection)	Frame, engine ground strap, or battery (-) terminal (Other chassis ground)
3	WHITE	Illumination power	Dash light switch or other switched and fused +12 volt vehicle power source
4	RED	Speedometer sensor power (supplied by gauge)	RED wire from speedometer SENSOR CABLE (refer to VDO Programmable Speedometer Instruction Sheet included with your kit)
5	BROWN	Speedometer signal	WHITE wire from speedometer SENSOR CABLE (refer to VDO Programmable Speedometer Instruction Sheet included with your kit)
6	BLUE	Oil pressure sensor signal	Engine oil pressure sensor terminal
7	GREEN	Temperature sensor	Engine temperature sensor terminal
8	GRAY	Fuel level sensor	Fuel level sensor terminal
(9)	VIOLET	Tachometer (optional)	Ignition coil (-) terminal, GM HEI "TACH" terminal, or other ignition tach output terminal (refer to ignition manufacturer's instructions)
PREWIRED	YELLOW	Speedometer signal (used for speedometer sensor included with your kit)	PREWIRED (in most cases you will not do anything with the yellow wire)

❖ If you choose to use a **different speedometer sensor** than the one supplied in your VDO Instrument Kit, you may be required to disconnect or change the yellow wire connection. REFER to the **VDO Programmable Speedometer Instructions** included with the kit. A spare terminal has been provided.

VDO Limited Warranty

VDO North America warrants all merchandise against defects in factory workmanship and materials for a period of 24 months after purchase. This warranty applies to the first retail purchaser and covers only those products exposed to normal use or service. Provisions of this warranty shall not apply to a VDO product used for a purpose for which it is not designed, or which has been altered in any way that would be detrimental to the performance or life of the product, or misapplication, misuse, negligence or accident. On any part or product found to be defective after examination by VDO North America, VDO North America will only repair or replace the merchandise through the original selling dealer or on a direct basis. VDO North America assumes no responsibility for diagnosis, removal and/or installation labor, loss of vehicle use, loss of time, inconvenience or any other consequential expenses. The warranties herein are in lieu of any other expressed or implied warranties, including any implied warranty of merchantability or fitness, and any other obligation on the part of VDO North America, or selling dealer.

(NOTE: This is a "Limited Warranty" as defined by the Magnuson-Moss Warranty Act of 1975.)

VDO North America · 188 Brooke Rd. · P.O. Box 2897 · Winchester, VA 22603 · Phone: 540-665-2428

VDO® North America

Instrument Kit Wiring Harness Installation Instructions

Please read all of these instructions and all of the instructions included with your VDO Instrument Kit before beginning the installation.

- Your VDO wire harness will help make the wiring portion of your VDO Instrument Kit installation easier, quicker and cleaner.
- Your VDO harness is prewired with connectors for all five gauges in your VDO Instrument Kit. The harness also is prewired with connectors for the addition of a VDO Tachometer.
- Easy to read wire COLOR CODE and CONNECTOR ILLUSTRATION CHARTS are provided. The charts are complete with all of the wires in the harness for your reference.
- But, you **only** need to connect **nine wires** to complete your installation (ten wires if you install a tachometer).

Recommended Installation:

- Disconnect the ground (-) cable from your vehicle's battery before making any electrical connections.
- Use the CONNECTOR

ILLUSTRATIONS to help identify which connector goes to which gauge.

- Plug the gauge harness connectors into the gauges.
- Plug the large 8-position and 4-position harness connectors into their mating vehicle harness connectors, if you have not already done so.
- Using the COLOR CODE CHART as a guide, route the loose ends of the wires from the vehicle harness to their connection points (fuse panel, sensors, etc.).
- Dress and secure the harness with zip ties (not included) or other means for an attractive installation that meets your liking.
- **Before cutting** any wires, double check your routing. Make sure the wires route to the correct connections and terminals.
- Cut wires to an appropriate length to make the final connections. Use care not to make the wires too short so that the connections are not strained.

- Make the final connections. Remember to follow the COLOR CODE table on the opposite page, and the CONNECTOR ILLUSTRATION CHARTS on the inside pages.

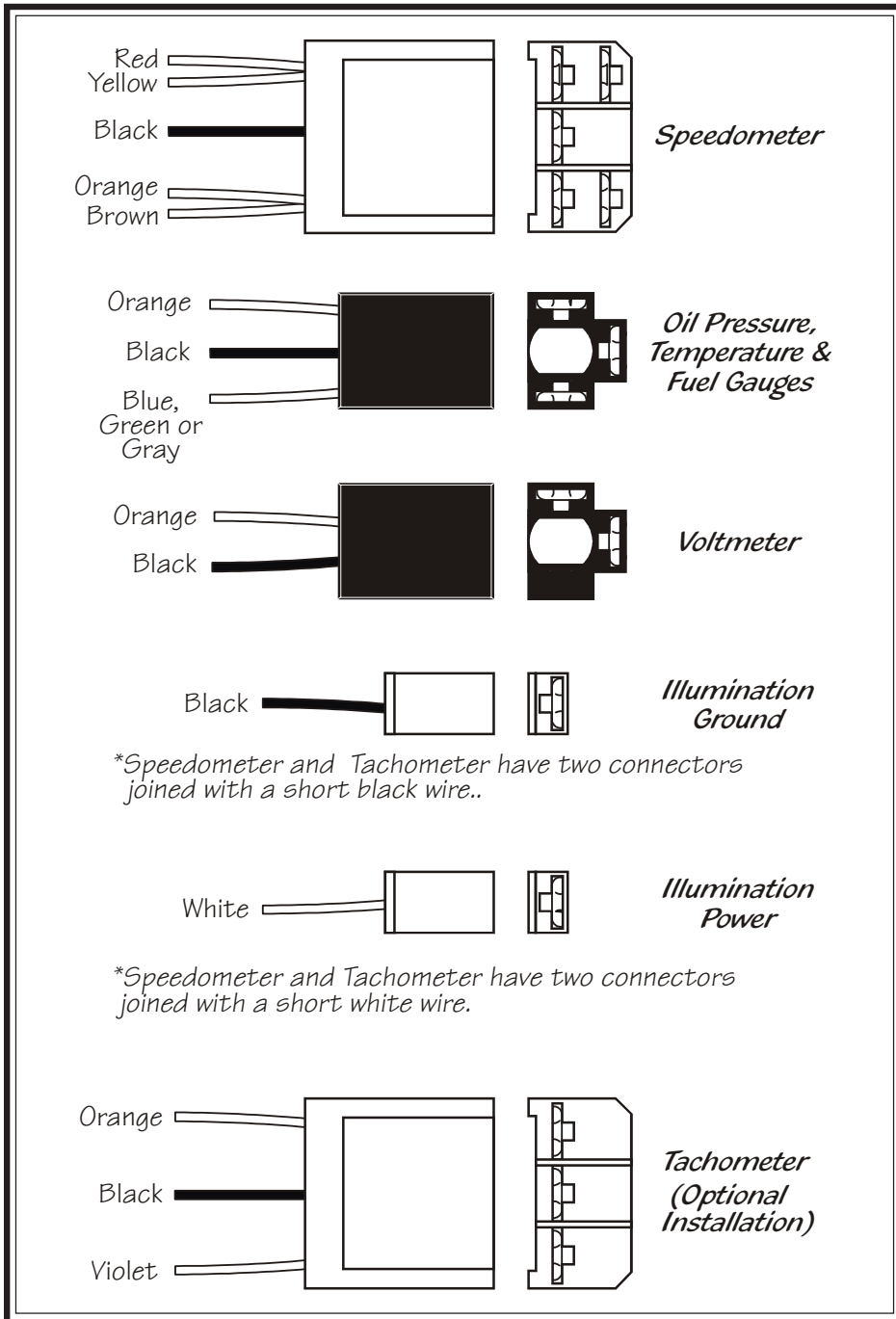

Diagram A
Gauge Harness

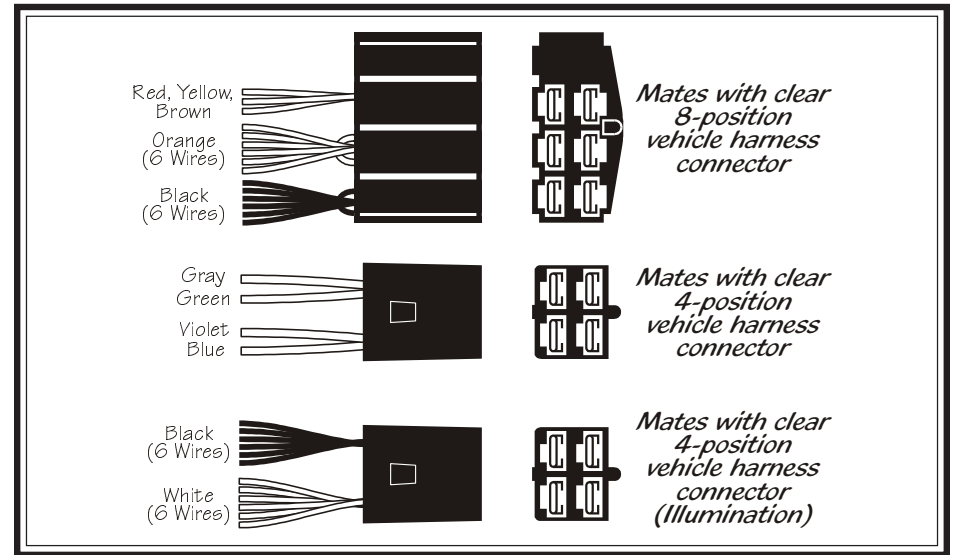

Diagram A, continued
Gauge Harness

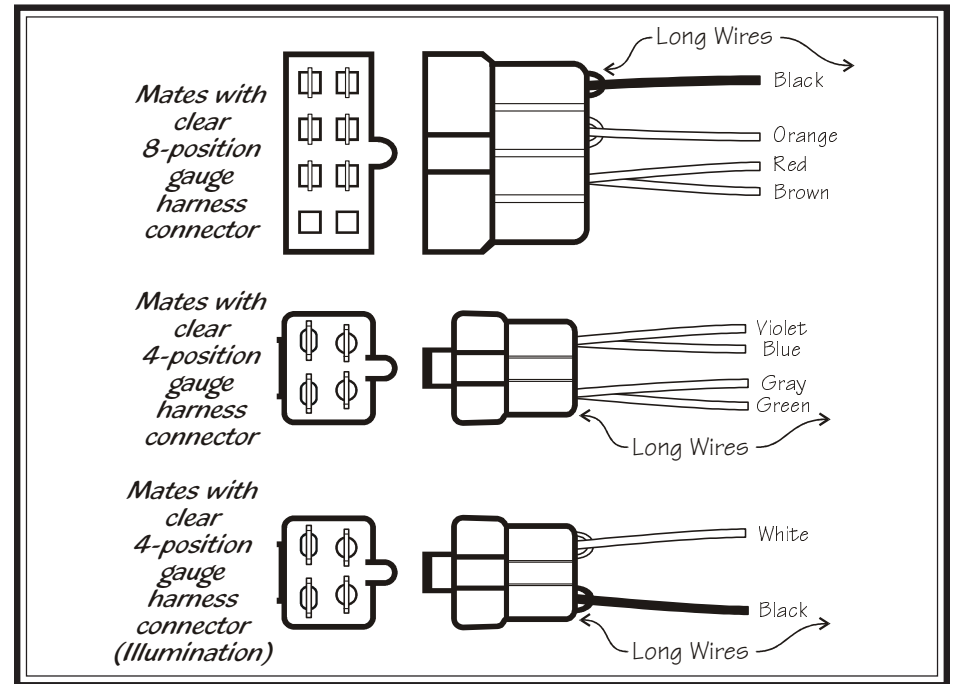

Diagram B
Vehicle Harness