

Diagram C
Proper wiring of the VDO Voltmeter

VDO Limited Warranty

VDO North America warrants all merchandise against defects in factory workmanship and materials for a period of 24 months after purchase. This warranty applies to the first retail purchaser and covers only those products exposed to normal use or service. Provisions of this warranty shall not apply to a VDO product used for a purpose for which it is not designed, or which has been altered in any way that would be detrimental to the performance or life of the product, or misapplication, misuse, negligence or accident. On any part or product found to be defective after examination by VDO North America, VDO North America will only repair or replace the merchandise through the original selling dealer or on a direct basis. VDO North America assumes no responsibility for diagnosis, removal and/or installation labor, loss of vehicle use, loss of time, inconvenience or any other consequential expenses. The warranties herein are in lieu of any other expressed or implied warranties, including any implied warranty of merchantability or fitness, and any other obligation on the part of VDO North America, or selling dealer.

(NOTE: This is a "Limited Warranty" as defined by the Magnuson-Moss Warranty Act of 1975.)

VDO North America · 188 Brooke Rd. · P.O. Box 2897 · Winchester, VA 22603 · Phone: 540-665-2428

1 BEGIN HERE

CAUTION: Read these instructions thoroughly before making installation. Do not deviate from assembly or wiring instructions. Always disconnect battery ground before making any electrical connections. If in doubt, please contact your dealer or VDO Instruments at (540) 665-2428.

IMPORTANT: Mounting dimensions vary for different gauges. Please be certain to follow the instructions for your specific gauge as described below.

Voltmeter Installation:

1. Select the location where you will mount the gauge, and mark a center point.

[text continues at #2] →

CAUTION!!!

These instructions contain information about gauges of different sizes. ***You must determine the size of your gauge before cutting any holes!***

Tools and Materials Needed For Installation:

16 Gauge stranded, insulated wire
Non-insulated ¼" spade connectors
2 ¼" hole saw or 2 ⅝" hole saw
Drill and drill bit set
Half-round file
Tape measure or ruler
Small tools: wrench or nut driver, utility knife, pliers, etc.

2. Cut a 2 ¼" (52 mm) diameter hole for all gauges **except** Pro Cockpit, which requires a 2 ⅝" (66 mm) hole. If the gauge is too snug, use a file to slightly enlarge the opening. (Diagram A)

3. Insert the instrument and secure it with either the VDO Spin-Lok™ clamp or mounting bracket. The Spin-Lok™ clamp can be reversed to accommodate various panel thicknesses. (Diagram B)

DO NOT OVERTIGHTEN.

Wiring the Voltmeter:

1. Run wires from the instrument location through the firewall to:

a) a positive (+), switched power source (i.e.: after the fuse box and the ignition switch, or any other switch.

Parts List

Item	Description	Quantity
1.	Voltmeter (2 ¼" [52 mm] diameter) Voltmeter (2 ⅝" [66 mm] diameter)	1 or 1
2.	Lamp Socket	1
3.	Light Bulb (12-volt)	1
4.	VDO Spin-Lok™ Clamp or VDO Mounting Bracket and nuts	1
5.	Installation Instructions	1

VDO® North America

Voltmeter Installation Instructions

Instruction Sheet #0 515 012 068
Rev.03/00

INSTRUCTIONS FOR THE INSTALLATION OF THE VOLTMETER ARE CONTAINED HEREIN. USE IS RESTRICTED TO 12 or 24-VOLT NEGATIVE GROUND ELECTRICAL SYSTEMS.

To Begin, go to #1

Gauge	Dimension "A"	Dimension "B"
Pro-Cockpit:	2 5/8" (66 mm)	2.77" (70 mm)
All other:	2 1/16" (52 mm)	2.19" (55.6 mm)

Table 1

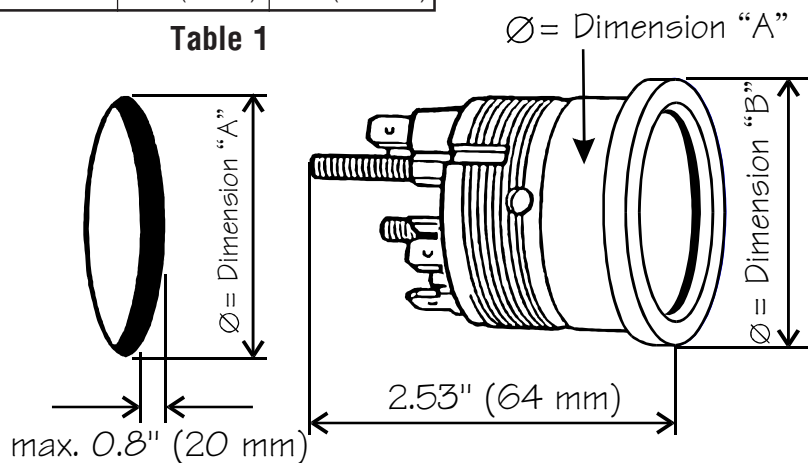

Pro-Cockpit, Industrial and Series 1 Gauges

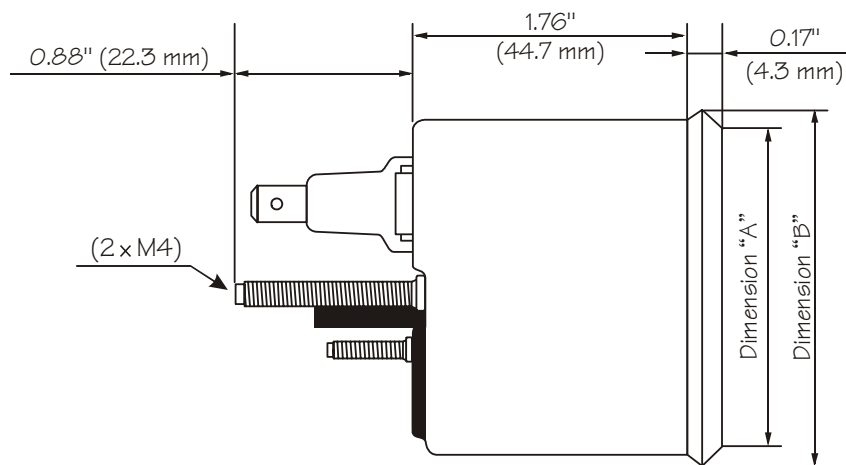

Diagram A
Gauge dimensions

2 CONTINUE HERE

This positive power source **MUST BE SWITCHED**, and must be protected with a fuse;

b) the light switch (also after the fuse in the fuse box); and

c) a good ground location .

2. Connect the positive (+) and negative [ground] (-) wires as shown in Diagram C.

3. Connect the appropriate positive (+)

and ground (negative [-]) wires to the terminals on the Voltmeter's lamp socket. Be sure that the ground wire from the lamp socket uses its own ground connection (separate from the one used by the gauge terminal ground), as shown in Diagram C.

At this point, the installation and wiring of your new VDO Voltmeter is complete. Turn on the ignition and the lights in the car and check to see that the instrument and light are working properly. If they aren't, re-check your wiring, referring to the wiring description in Diagram C.

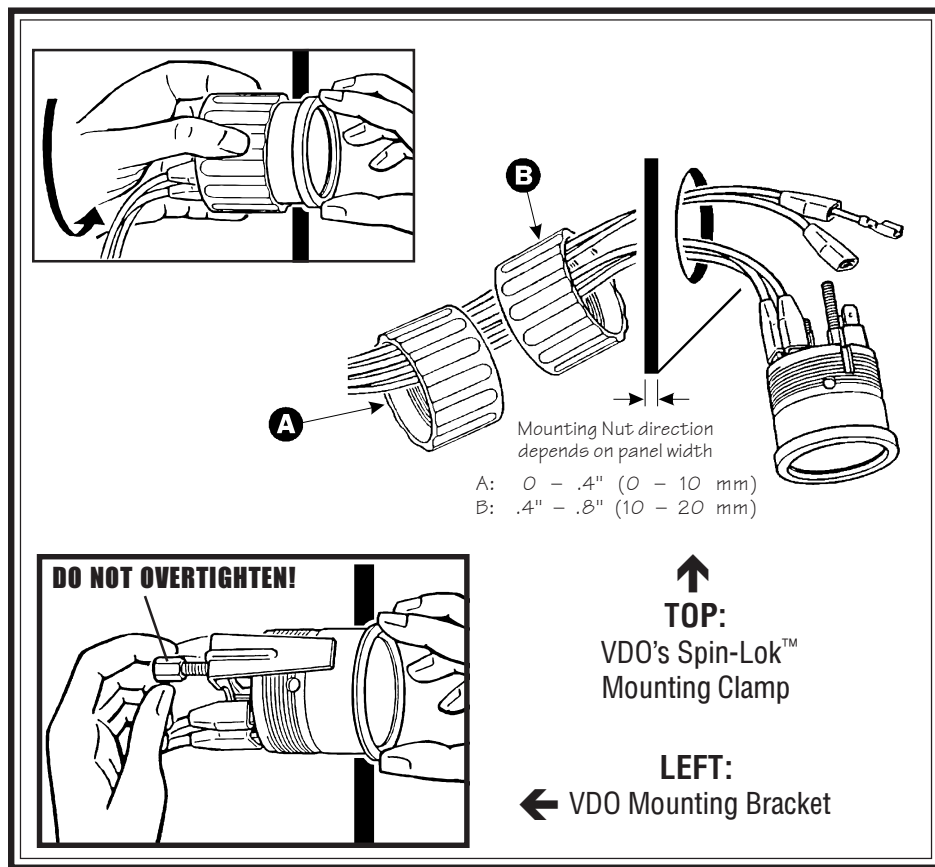

Diagram B
Mounting using VDO Mounting Bracket or VDO Spin-Lok™ Clamp