

Diagram C

Proper mounting of the VDO Mechanical Temperature Gauge

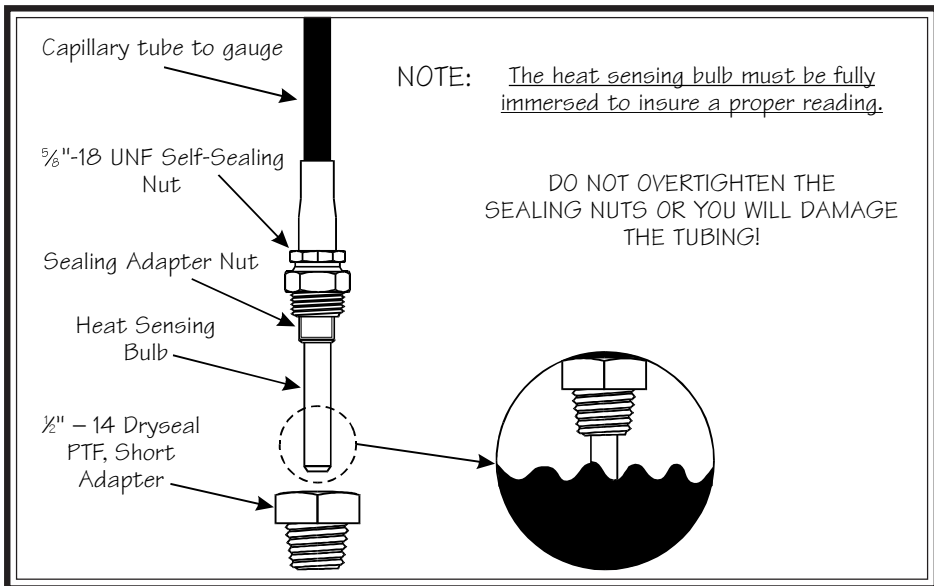

Diagram D

Proper installation of adapter and heat sensing bulb

VDO Limited Warranty

VDO North America warrants all merchandise against defects in factory workmanship and materials for a period of 24 months after purchase. This warranty applies to the first retail purchaser and covers only those products exposed to normal use or service. Provisions of this warranty shall not apply to a VDO product used for a purpose for which it is not designed, or which has been altered in any way that would be detrimental to the performance or life of the product, or misapplication, misuse, negligence or accident. On any part or product found to be defective after examination by VDO North America, VDO North America will only repair or replace the merchandise through the original selling dealer or on a direct basis. VDO North America assumes no responsibility for diagnosis, removal and/or installation labor, loss of vehicle use, loss of time, inconvenience or any other consequential expenses. The warranties herein are in lieu of any other expressed or implied warranties, including any implied warranty of merchantability or fitness, and any other obligation on the part of VDO North America, or selling dealer.

(NOTE: This is a "Limited Warranty" as defined by the Magnuson-Moss Warranty Act of 1975.)

VDO North America · 188 Brooke Rd. · P.O. Box 2897 · Winchester, VA 22603 · Phone: 540-665-2428

1 BEGIN HERE

CAUTION: Read these instructions thoroughly before making installation. Do not deviate from assembly or wiring instructions. Always disconnect battery ground before making any electrical connections. If in doubt, please contact your dealer or VDO Instruments at (540) 665-2428.

General Information:

Your VDO mechanical temperature gauge features the latest illumination technology and a rugged design to insure years of durable and reliable operation. These instruments come with capillary tubing attached, but may require adapters to complete installation with various engines. You may purchase these adapters from your VDO dealer.

CAUTION!!!

These instructions contain information about gauges of different sizes. **You must determine the size of your gauge before cutting any holes!**

Tools and Materials Needed For Installation:

- 16 Gauge stranded, insulated wire
- Non-insulated 1/4" spade connectors
- 2 1/16" hole saw
- Drill and drill bit set
- Half-round file
- Tape measure or ruler
- Small tools: wrench or nut driver, utility knife, pliers, etc.
- Various engine adapters

Gauge Installation:

1. Insert the light bulb into the lamp socket. Snap the socket into the socket hole on the back of the gauge. (Diagram A)
2. Select the location where you will mount the gauge, and mark a center point.
3. Cut either a 2 1/16" (52 mm) or a 2 5/8" (66 mm) diameter hole, depending on which gauge you are installing. Place the instrument into the hole. If the gauge is too snug, use a file to slightly enlarge the opening until the gauge fits properly. See Diagram B.
4. Slip the mounting brackets over the mounting bolts on the back of the gauge. Screw on the accompanying nuts. Use a wrench to tighten the nuts until the gauge can no longer be rotated by hand. DO NOT OVERTIGHTEN! (Diagram C)

[text continues at #2] ➔

Parts List

Item	Description	Quantity
1.	Temperature Gauge (2 1/16" [52 mm] diameter) 1 or Temperature Gauge (2 5/8" [66 mm] diameter) 1	1
2.	Lamp Socket (Push in, wedge-type)	1
3.	Light Bulb (12-volt / G.E. #158 or equivalent)	1
4.	VDO Mounting Bracket and nuts	1
5.	Installation Instructions	1

VDO® North America

Mechanical Temperature Gauge

Installation Instructions

Instruction Sheet #0 515 012 109
Rev.03/00

INSTRUCTIONS FOR THE INSTALLATION OF THE MECHANICAL TEMPERATURE GAUGE ARE CONTAINED HEREIN. USE IS RESTRICTED TO 12-VOLT NEGATIVE GROUND ELECTRICAL SYSTEMS. LIGHT BULB, IF SUPPLIED, IS 12 VOLTS.

To Begin, go to #1

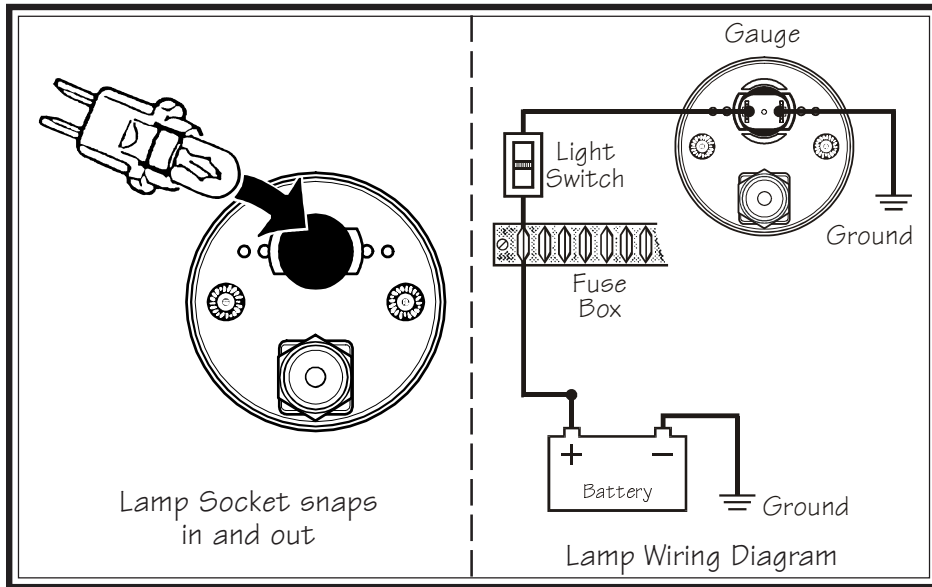

Diagram A

Proper installation and wiring of lamp socket on all gauges

2 CONTINUE HERE

Gauge Hookup and Lamp Wiring:

1. Drill a $\frac{7}{8}$ " hole in the firewall. Route the capillary tube from the gauge through the hole in the firewall to the engine. **DO NOT CRIMP** the tubing closed during routing. A rubber grommet is recommended around the tubing where it passes through the firewall.
2. Determine whether you will need the supplied $\frac{1}{2}$ " adapter to connect the capillary tube to the engine. (See Diagram D)
3. If you do not need any adapters, attach the tubing to the engine using the $\frac{1}{4}$ " self-sealing nut. If you need the $\frac{1}{2}$ " adapter, install it in the engine port. Then insert the heat sensing bulb and sealing nut into the $\frac{1}{2}$ " adapter and carefully tighten the sealing nut. (See a VDO catalog if a different type of adapter is necessary.) **DO**

NOT OVERTIGHTEN THE SEALING NUT OR YOU WILL DAMAGE THE TUBING!

4. Wire the light socket. (Diagram A)

At this point, installation is complete. Before starting the engine, re-check the routing of the tube from gauge to engine.

CAUTION:

MAKE SURE THE TUBE IS ABSOLUTELY FREE FROM MOVING AND/OR HOT ENGINE COMPONENTS, AND THAT IT IS TOTALLY FREE OF KINKS.

Start the engine and turn on the lights to make sure there are no leaks and that the gauge illumination functions properly. If it doesn't, recheck your connections and your wiring. Check tubing connections for leaks.

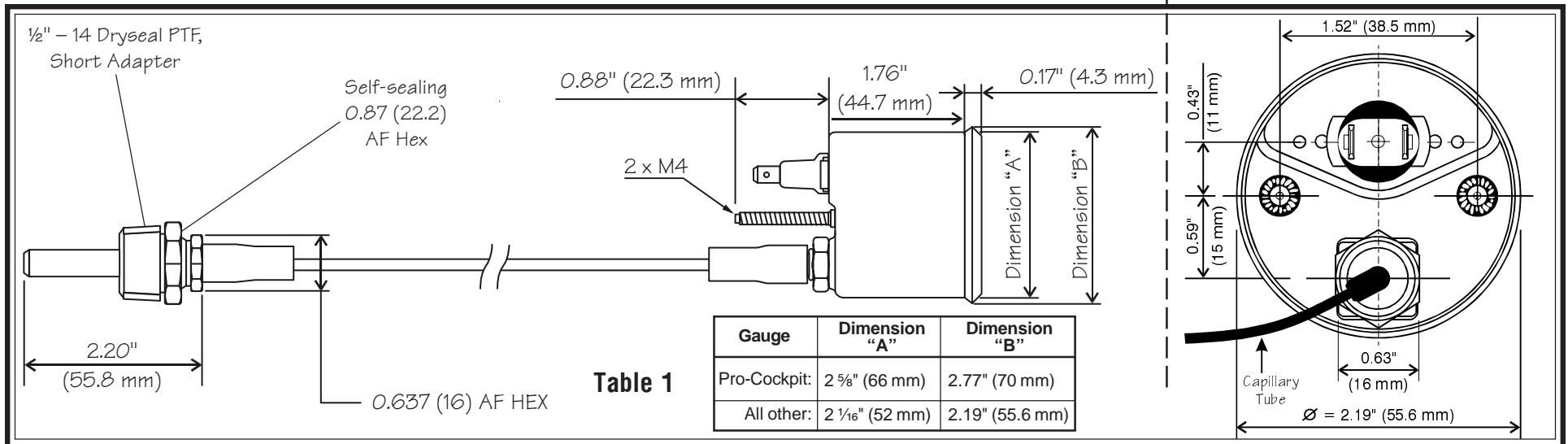

Diagram B

Gauge dimensions